

**FOR SAFE USE OF YOUR LENS****1**

Although we have carefully designed these lenses for safe operation, please pay special attention to items marked with the following symbols when using this product.

**WARNING**

This symbol indicates precautions that if not followed, could result in serious injury to the user.

**CAUTION**

This symbol indicates precautions that if not followed, could result in minor or medium injury to the user or damage to the equipment.

**WARNING**

- **Never look at the sun through the lens or camera. Serious damage to the retina or total loss of eyesight may occur.**

**CAUTION**

- **Do not leave the lens in direct sunlight without lens caps. Direct sunlight passing through the lens will be intensified, and should it focus on flammable materials, fire may occur.**

**2****PRECAUTIONS AND LENS MAINTENANCE**

1. Storage and mildew prevention
  - Take the lens out of the protective case or camera bag, and store it in a dry, well-ventilated place.
  - Avoid storing the lens in a poorly ventilated location such as a closet, wardrobe, drawer, vehicle, or where insect repellent or medicine is kept.
  - Avoid storing the lens in areas of high temperature and humidity, where there is a risk of mildew growth. Store the lens with a desiccant in a dry cabinet, airtight container, or plastic bag. (Leaving a saturated desiccant in the storage container can cause damage to the lens. Be sure to read the instructions that come with the desiccant before use.)
2. The lens is not waterproof. When using the lens in a rain or mist, be careful not to allow it to get wet.
3. Never use any organic solvent such as thinner, alcohol, or benzene, etc. to remove dust on the lens.
4. The lens is a precise optical instrument. Be careful not to let it fall, or subject it to strong shocks or pressure. Use a cushion or similar pad to protect the lens from the vibrations of motorcycles or other vehicles, boats, etc.
5. Avoid subjecting the lens to rapid changes in temperature, otherwise condensation can occur on both the inside and the outside of the lens. Put the lens in a plastic bag or camera bag, and take it out after the lens has reached ambient temperature.
6. When the lens is not attached to the camera body, attach both the supplied lens cap and lens mount cap to protect it from dust.
7. Do not leave the camera with the lens cap off attached to a tripod or other rigid camera support. The inner parts of the camera can be damaged by direct sunlight.
8. Have the lens inspected by a dealer every one or two years to maintain its high performance.

# CONTENTS

**3**

◦ FOREWORD	
◦ FOR SAFE USE OF YOUR LENS	1
◦ PRECAUTIONS AND LENS MAINTENANCE	2
◦ smc PENTAX-DA LENS	4
• About the DA Lens Mount	5
◦ MOUNTING AND REMOVING THE LENS	6
◦ LENS CAP	7
◦ FOCUSING	8
• Changing the Focus Mode	8
• Using Autofocus	8
• Focusing with the OK Button	9
• Using Manual Focus	10
• Using the Quick-Shift Focus System ( <i>*istD</i> -series cameras only)	11
• How to use the Quick-Shift Focus System	11
• Precautions on close-distance scale	13
◦ ZOOM LENS	14
• About the zoom ring	15
◦ ATTACHING THE LENS HOOD	16
• Screw-on Type	16
• Bayonet Type	16
• About the PL filter window	17
◦ FILTERS	19
◦ PRECAUTIONS WHEN USING THE LENS WITH A FLASH	21
• Built-in Flash	21
• External Flash	21
• Compatibility of DA Lenses with the Built-in Flash	22
◦ MAIN SPECIFICATIONS	23

## 4

## smc PENTAX-DA LENS

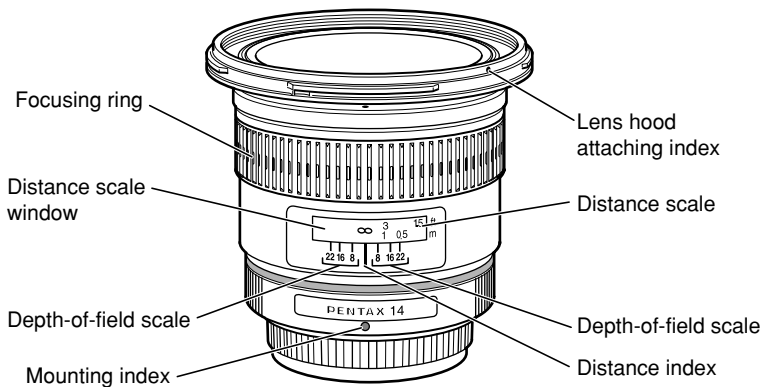
**Note:**

The DA lens does not have an aperture ring. Aperture settings are controlled automatically as if set to the auto "A" position, so accessories without an auto "A" setting cannot be used with this lens.

### About the DA lens mount

The DA lens is an interchangeable lens specifically designed for the PENTAX *\*istD* - series digital SLR camera.

The K<sub>AF</sub>-mount of the DA lens is similar to conventional SLR lenses, but the DA lens cannot be used on 35 mm SLR cameras.

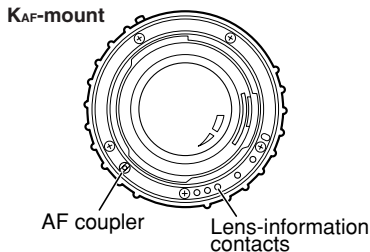

### CAUTION

Be careful not to damage or dirty the lens-information contacts and AF coupler on the mount surfaces of the camera and lens. Otherwise, failure or malfunction may result.

## 6

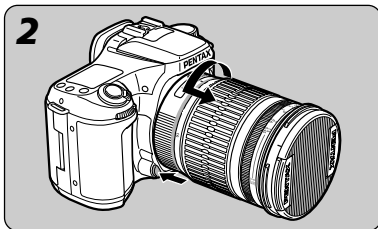
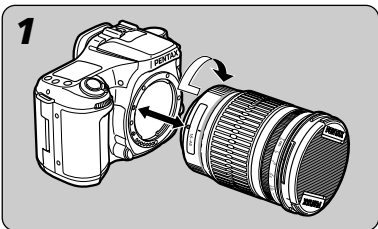
**MOUNTING AND REMOVING THE LENS****1. To mount the lens on the camera body**

Attach the lens while aligning the red dots on the lens and body, then turn the lens clockwise until it clicks in place.

**Memo:**

- Do not hold down the lens unlock button while mounting the lens, otherwise the lens will not be properly mounted.
- After mounting the lens, gently turn the lens counterclockwise to make sure it is locked in place.

**2. To remove the lens**

Hold down the lens unlock button on the camera body and turn the lens counterclockwise.

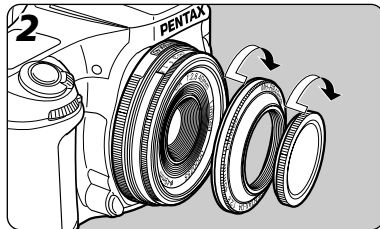
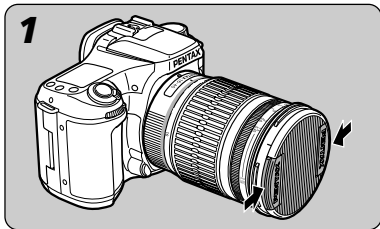
**LENS CAP****7**

- 1.** Take off the lens cap by pressing the two tabs inward as shown above.
- 2. Attaching the dedicated lens cap to DA 40mm f/2.8 Limited**  
First screw the dedicated hood onto the front of the lens, then screw on the lens cap.

** Memo:**

- When not using the lens, be sure to attach the lens cap.

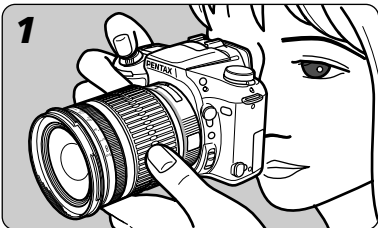

### Changing the Focus Mode

Use the camera's focus mode switch to change between the autofocus mode and manual-focus mode. For details, refer to your camera's manual.

#### 1. Using Autofocus

Set the camera's focus mode to autofocus. Press the shutter button halfway to autofocus.

With the *\*istD* camera, you can also press the AF button to autofocus.



### Focusing with the OK Button

With the *\*istDL* or *\*istDS* camera set as explained below, autofocus by pressing the shutter button halfway will be disabled and the OK button can be used instead to autofocus.

*\*istDL*, *\*istDS* : On the **C** Custom menu, select “Enable AF” for “OK btn when shooting”.

#### Memo:

- For details on the setting procedure, refer to the camera's instruction manual.

#### **CAUTION**

During autofocus, the focusing ring of following lenses will rotate.

- **To prevent malfunction, do not touch the focusing ring during autofocus.**

- DA 16-45mm f/4ED AL  
- DA 50-200mm f/4-5.6ED

- DA 18-55mm f/3.5-5.6 AL  
- DA 40mm f/2.8 Limited

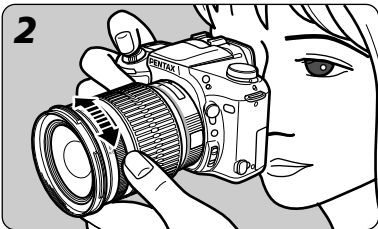

## 2. Using Manual Focus

Set to MF with the camera's focus mode, and turn the focusing ring to focus manually.

## Using the Quick-Shift Focus System (*\*istD* -series cameras only)

If you use the lens with an *\*istD* -series camera and the focus mode is set to autofocus, you can focus manually after autofocus is achieved. Just turn the focusing ring to manually touch-up the focus. You can do this without changing the focus mode to MF.

### How to use the Quick-Shift Focus System

#### 1. Using Autofocus

Set the camera's focus mode switch to autofocus, then press the shutter button halfway to autofocus.

With the *\*istD* camera, you can also press the AF button to focus.

With the *\*istDL* or *\*istDS* camera set as explained by "Focusing with the OK Button" on page 9, you can focus by pressing the OK button.

- 2. Hold down the shutter button halfway (or hold down the AF button or OK button), then turn the focusing ring to focus.**
- 3. Finally, press the shutter release button fully to take a picture.**

**CAUTION**

During autofocusing, the focusing ring of following lenses will rotate.

- **To prevent malfunction, do not touch the focusing ring during autofocusing.**
  - DA 16-45mm f/4ED AL
  - DA 18-55mm f/3.5-5.6 AL
  - DA 50-200mm f/4-5.6ED
  - DA 40mm f/2.8 Limited
- When using the Quick-Shift Focus System, keep pressing the shutter button (or AF button) after you achieve focus and before taking a picture. If you let go of the shutter button before taking the picture, you will have to focus all over again when you press the shutter button again.

In the following cases, you can take the picture without autofocusing after letting go of the shutter button.

- With the *\*istD*, set the “AF with Press Halfway” Custom Function to off. To autofocus, press the AF button.
- With the *\*istDL* and the *\*istDs* camera, use the **C** Custom menu to set “AF cancel” for “OK btn when shooting”. This will enable you to focus manually while you hold down the OK button.

The setting procedure and more details are explained in the camera's instruction manual.

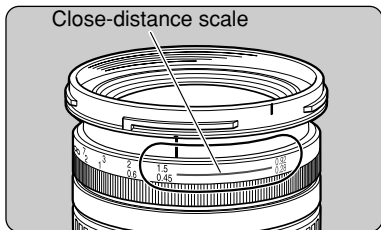

### **Precautions on close-distance scale**

#### **(For DA 16-45mm f/4ED AL, DA18-55mm f/3.5-5.6 AL)**

In the close-distance scale range (the distance scale in the orange area), when shooting at the maximum aperture, image quality deterioration in the picture corners may result because of the optical characteristics of the lens.

When taking a picture in this range, we recommend that you use a smaller aperture, stopping down from wide open.

## ZOOM LENS

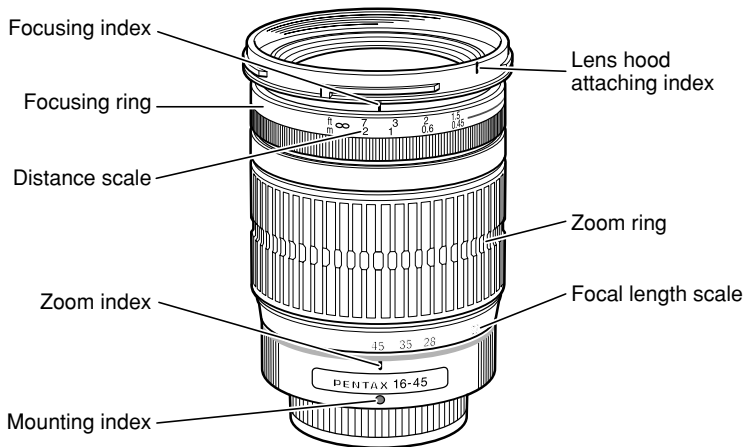

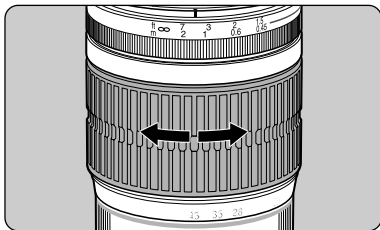

The zoom lens has a focusing ring at the front and a zoom ring behind it. Turn the zoom ring to set the desired angle of view (lens focal length).

 **Memo:**

- The focusing point may shift slightly by changing the focal length. First adjust the zoom and then adjust focus.

**About the zoom ring**

Turn the zoom ring clockwise for telephoto and counterclockwise for wide-angle.

## ATTACHING THE LENS HOOD

In order to avoid the deterioration in image quality from internal reflection, use of the lens hood is recommended.

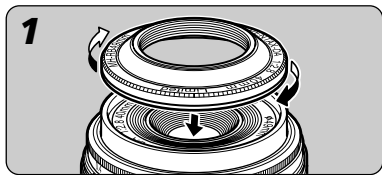

### 1. Screw-on Type

If the lens hood is dedicated to the DA 40mm f/2.8 Limited, screw it onto the front of the lens.

### 2. Bayonet Type

When attaching the lens hood, align the index on the lens hood with the attaching index on the lens, and push both parts straight toward each other. Attach the lens hood on the lens by turning the hood in the clockwise direction to lock it as viewed from the front of the lens until it clicks into position.

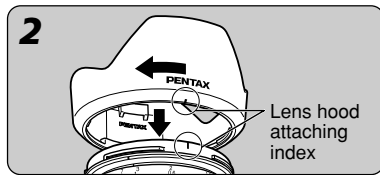

### Memo:

- When attaching the lens hood, hold the focus ring and zoom ring securely to prevent them from turning.
- When the lens hood is not in use, it can also be turned around and attached in the reversed position.



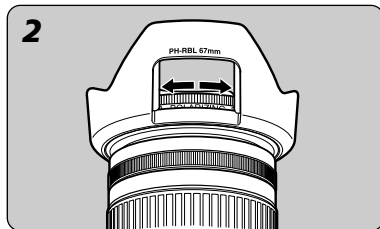
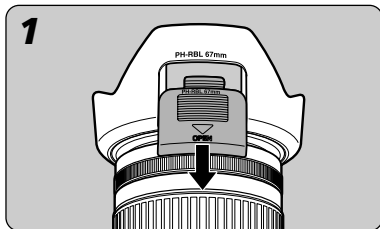

### About the PL filter window

If a circular polarizing filter is attached to the DA lens, you can easily turn the filter via the PL filter window on the bayonet-type hood.

### How to use the lens hood with polarizing filter window

1. Remove the PL filter window cap by sliding it in the direction as shown above.
2. Turn the outer rim of the circular polarizing filter from the PL filter window as shown above.

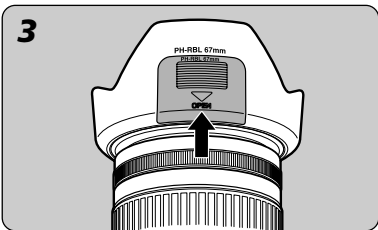

**3.** Attach the PL filter window cap.

 **Memo:**

- When shooting, be sure the PL filter window cap is in place to make that the lens hood is being used to maximum effect.

## FILTERS

19

Make sure the filter size matches the lens, then screw the filter onto the front of the lens.

### **Memo:**

- The compatible filter size for all the lenses are listed on pages 23-24.

### **Precaution on filters**

- Since the filter becomes a part of the optics when attached on the lens, handle it in the same way you handle the lens with care to dust, dirt and scratches. Normally, attaching two or more filters on a lens is not recommended. However, attaching a circular polarizing filter and another filter would not be a problem.
- Use a circular polarizing filter with Autofocus camera for proper exposure and autofocusing.

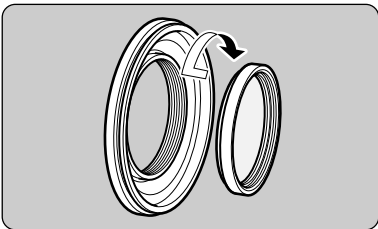

### **Attaching the 30.5mm filter to the DA 40mm f/2.8 Limited lens**

Normally, you attach the 49mm filter to the front of the lens. But as shown in the diagram, you can also screw on a 30.5mm filter to the back of the dedicated hood.

### **About Using a Circular Polarizing Filter**

- If you attach an older type Pentax circular polarizing filter to the DA 16-45mm f/4 ED AL, DA 18-55mm f/3.5-5.6 AL or DA 50-200mm f/4-5.6ED lens, the dedicated hood cannot be attached over the filter. Also, the hood might or might not be attachable if a non-Pentax circular polarizing filter is attached to the lens.
- Do not attach an older type Pentax circular polarizing filter to the DA 14mm f/2.8 ED (IF). The filter will cause vignetting. Instead, use the new Pentax circular polarizing filter which will not cause vignetting.

## PRECAUTIONS WHEN USING THE LENS WITH A FLASH

21

### Built-in Flash

The built-in flash can not be used when the distance is less than 0.7m. When the flash is used within 0.7m, it causes incorrect exposure control and vignetting in the picture corners.

- Refer to the “Compatibility of DA Lenses with the Built-in Flash” chart on page 22 for information on the compatibility of the built-in flash with the lens being used. Furthermore, please note that when using the *\*istD* -series camera, a warning indication does not appear even when taking a picture with a built-in flash that is incompatible with the lens being used.
- If the built-in flash is used with the lens hood attached to the lens, the flash light will be blocked by the lens hood. Always make sure to remove the lens hood before using the built-in flash.

### External Flash

#### ● DA 14mm f/2.8ED (IF)

The AF360FGZ external flash unit with the wide-angle panel only can be used, and the lens hood can be attached as well. Other external flash units are not recommended to use because their coverage angle is not compatible with the angle of view of the lens.

#### ● DA 16-45mm f/4ED AL, DA18-55mm f/3.5-5.6 AL, DA50-200mm f/4-5.6 ED, DA 40mm f/2.8 Limited

When using the external flash unit, the vignetting will not occur with the lens hood attached to the lens if the flash covers its angle up to 24 mm (equivalent in 35mm format).

For further details, refer to the operating manual for your external flash unit.

### Compatibility of DA Lenses with the Built-in Flash

Lens	Compatibility	Remarks
14mm f/2.8ED (IF)	No	
40mm f/2.8 Limited	YES	
16-45mm f/4ED AL	*YES	*Vignetting may occur at a focal distance less than 28mm, and also may occur at a focal distance 28mm when object distance is less than 1m.
18-55mm f/3.5-5.6 AL	YES	
50-200mm f/4-5.6ED	YES	

When using the built-in flash, be sure to detach the lens hood before shooting. This is to prevent obstruction of the flash coverage.

## MAIN SPECIFICATIONS

23

Lens	DA 14mm f/2.8ED (IF)	DA 40mm f/2.8 Limited	DA 16-45mm f/4ED AL
Focal length	14 mm (equivalent to 21.5mm in 35mm format)	40 mm (equivalent to 61mm in 35mm format)	16-45 mm (equivalent to 24.5-69mm in 35mm format)
Usable camera	<i>*istD</i> -series	<i>*istD</i> -series	<i>*istD</i> -series
Elements in groups	12-11	5-4	13-10
Angle of view	90°	39°	83°-35°
Aperture	f/2.8	f/2.8	f/4
Minimum aperture	f/22	f/22	f/22
Mount type	K <sub>AF</sub> -mount	K <sub>AF</sub> -mount	K <sub>AF</sub> -mount
Minimum focus distance	0.17m (0.56ft)	0.4m (1.31ft)	0.28m (0.92ft)
Maximum magnification	Approx. 0.19×	Approx. 0.13×	Approx. 0.26×
Filter size	77mm	49mm or 30.5mm	67mm
Lens hood	PH-RBH 77mm	MH-RC 49mm	PH-RBL 67mm
Max. Diameter × Length	83.5mm × 69mm (3.3in × 2.7in)	63mm × 15mm (2.5in × 0.6in)	72mm × 92mm (2.8in × 3.6in)
Weight	420g /14.8oz (with hood 455g /16oz)	90 g /3.15oz (with hood 100 g /3.5oz)	365g /12.9oz (with hood 390g /13.8oz)
Soft case	S100-120	Dedicated case	S90-140

Lens	DA18-55mm f/3.5-5.6 AL	DA 50-200mm f/4-5.6ED
Focal length	18-55 mm (equivalent to 27.5-84mm in 35mm format)	50-200 mm (equivalent to 76.5-306mm in 35mm format)
Usable camera	<i>*istD</i> -series	<i>*istD</i> -series
Elements in groups	12-9	11-10
Angle of view	76°-29°	31.5°-8.1°
Aperture	f/3.5-f/5.6	f/4-f/5.6
Minimum aperture	f/22-f/38	f/22-f/32
Mount type	K <sub>AF</sub> -mount	K <sub>AF</sub> -mount
Minimum focus distance	0.25m (0.82ft)	1.1m (3.6ft)
Maximum magnification	Approx. 0.34×	Approx. 0.24×
Filter size	52mm	52mm
Lens hood	PH-RBA 52mm	PH-RBB 52mm
Max. Diameter × Length	68mm × 67.5mm (2.7in × 2.6in)	66.5mm × 78.5mm (2.6in × 3.1in)
Weight	225 g /7.9oz (with hood 250 g /8.8oz)	255 g /9oz (with hood 285 g /10oz)
Soft case	S80-120	S80-120